

Operating instructions Diaphragm pump MP-100

DOK-237-GB Rev. 3

Article No. 6500-000

-keep for further use-

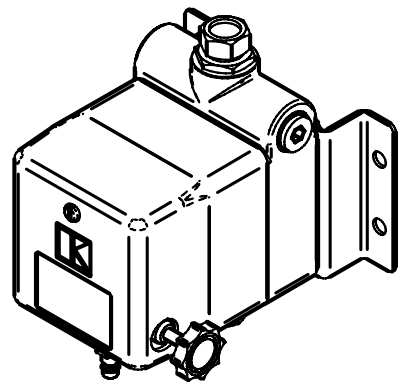

Krautzberger 

Contents

1	USE FOR INTENDED PURPOSE	3
2	GENERAL SAFETY NOTES	3
2.1	Important when using hazardous substances:.....	4
3	FUNCTIONAL PRINCIPLE.....	4
4	INSTALLATION	5
5	STARTUP.....	5
6	CLEANING.....	6
7	SHUTDOWN DURING INTERRUPTIONS TO WORK	6
8	DISPOSAL.....	6
9	TROUBLESHOOTING	6
10	REGULAR CHECKS.....	7
10.1	Diaphragms and gaskets	7
10.2	Hoses and pipelines	7
11	MAINTENANCE	7
11.1	Replacing the diaphragm and valve parts [Drawings on page 10-13].....	7
11.2	Replacing valve parts [Drawings on pages 10-13].....	8
12	TECHNICAL DATA	8
13	SPARE PARTS LIST	11
14	TROUBLESHOOTING	12
15	ACCESSORIES	13
15.1	Suction devices (flexible).....	14
15.2	Suction devices (angled, flexible)	15
15.3	Suction devices (rigid)	16
15.4	Pressure equalisation tank	17
15.5	Pressure pipe.....	18

1 USE FOR INTENDED PURPOSE

The diaphragm pump MP-100 is a pump driven by compressed air and is designed exclusively for the:

- conveying of liquid and low-viscosity coating material from pressureless storage containers
- supply of material to spray guns, automatic spray guns, metering devices and similar

It is mainly used for painting and coating operations.

Material conveying properties

Material	Suitability
Paints (containing solvents)	good
Water-based paints, dispersion paints, Latex, wood preservative	good
Water	good
Oils, fuel oil, diesel oil	good
Emulsions, soaps, detergents	good
Alcohol, glazing agents	with qualifications
Lime slurry	with qualifications
Cellulose and fibrous materials	unsuitable
Paste Sludge, mash, paste	unsuitable

In case of doubt, ask about the suitability of non-listed materials. In special cases, we conduct trials to determine suitability.

2 GENERAL SAFETY NOTES



Diaphragm pumps may only be used in line with the operating parameters (pressure, temperature etc.) specified under "Technical data"!



The operator must check the compatibility of the pump materials with the coating substance to be used. To ensure compatibility, refer to the safety data sheet supplied by the manufacturer of the coating substance!



All work connected with installation and maintenance must be performed by suitably qualified personnel. Always use original parts when replacing worn or damaged parts.



Each time before you start working, check the material and compressed air connections for firm seat and damage! Loose, pressurised hoses may cause accidents due to whiplash-like movement and the discharge of fluids.



Never point compressed air at people or animals!



Highly abrasive, chemically aggressive, extremely hot or extremely cold materials may only be used in consultation with Krautzberger GmbH!



After the material has been used up, the pumps may only be operated at low pressure (< 4 bar) – set on the air regulator.
No-load operation increases wear and may destroy the pump!
Ensure that the material container is always sufficiently full!

2.1 Important when using hazardous substances:



Always comply with the stipulations in the safety data sheet of the manufacturer of the coating substance. In particular, adhere to instructions relating to:

- the wearing of personal protective equipment
- the avoidance of explosive or harmful environments



Electrostatic charges during operation of the pump can lead to electric shocks and spark formation.

The pump must therefore be earthed!

Also earth air pipes, operating equipment and electrically conductive surfaces in the working zone.

Connected hose lines must be conductive (<1 Mega-Ohm) and must also be earthed.



Rooms in which hazardous substances are stored or processed must have adequate ventilation. It may be necessary to install a technical ventilation system.

If the ventilation system fails, work must be stopped immediately and the pump switched off.

In such cases, always comply with the national and regional regulations.



Do not store any flammable substances, empty coating substance containers or other materials that have been in contact with the coating substance (paper, cloths etc.) in the working zone of the pump.



Do not use halogenated detergents. Chemical reactions may create explosive and caustic compounds!



In the working zone, avoid open flames and red-hot components as well as equipment, tools and parts that can create ignitable sparks.



Hang up “No Smoking” signs in a 5 metre radius of the working zone!
make fire extinguishers available if these are not already in place!



Comply with all national and regional water protection regulations!
Comply with all national and regional waste disposal regulations!

3 FUNCTIONAL PRINCIPLE

The pump consists of the diaphragm housing, the compressed air controller, material suction and pressure connection, compressed air connection and air regulator.

The pressure desired at the extraction point can be adjusted steplessly via the air regulator.

As soon as the set material pressure is reached, the pump switches off automatically.

The material pressure is maintained until material is extracted at the extraction point. The pump switches on automatically and keeps the set material pressure constant.

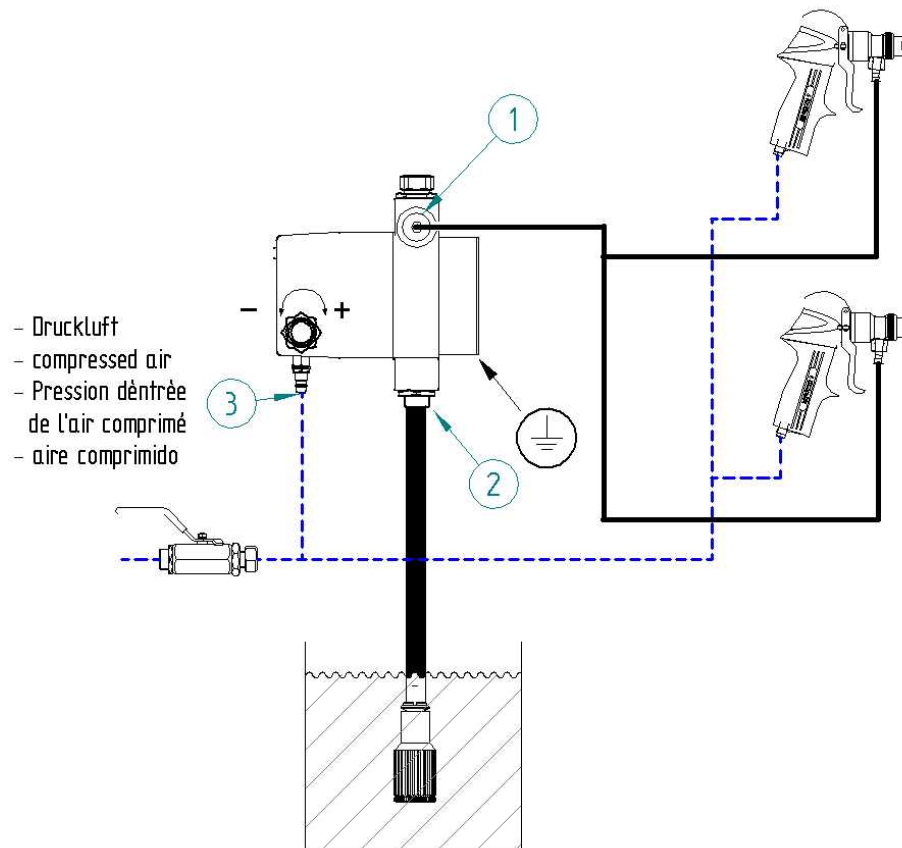

4 INSTALLATION

Mount the pump vertically (material inlet at bottom!) on a wall or a suitable supporting structure. Correct operation of the pump is only assured if it is mounted vertically.

- Connect the material suction hose to the material inlet (2)
- At the material outlet, connect the material pressure hose to your extraction point (1)

- Connect the compressed air supply at the air connection (3)

The compressed air supply must be dry, oil-free and protected using an overpressure valve. Make the necessary provision for a suitable shutoff device (ball valve etc.) to permit fast switch-off in the event of malfunction.

- Connect the earthing device.

CHECK THE FIRM SEAT OF ALL CONNECTIONS!

5 STARTUP

Ensure that:

- an air pressure of 4-8 bar is present at the compressed air connection.
- the material suction hose is immersed in the material.

The first time the unit is started up, there is air in the pump and in the supply line. The wear on the pump is particularly strong during no-load operation. You should therefore set a low air inlet pressure on the air regulator at the start. Activate the extraction point until material is discharged.

After performing venting, set the desired material pressure using the air regulator.

6 CLEANING

Thoroughly clean the pump after use. Immerse the material suction hose in a suitable detergent.

OBSERVE THE SAFETY INSTRUCTIONS OF THE DETERGENT MANUFACTURER. DETERGENTS CAN BE HARMFUL TO YOUR HEALTH AND MAY BE HIGHLY FLAMMABLE!

Rinse the pump through by activating the extraction point. To ensure that material residues do not harden, you should leave the **detergent** in the pump until the next time it is used.

7 SHUTDOWN DURING INTERRUPTIONS TO WORK

- Clean the pump as described above.
- Close the air regulation wheel by turning to the left.
- Interrupt the compressed air feed at a suitable point in your system.

Dissipate any remaining material pressure by activating the material extraction point.

8 DISPOSAL

Clean the pump if necessary to ensure that no residues of toxic, flammable or explosive material remain in the housing.

After dismantling the pump:

Dispose of the individual components through the appropriate recycling channels.

Please observe the regulations of the local disposal companies.

9 TROUBLESHOOTING

Defect	Cause	Remedy
Air bubbles in material container	Loose/Leaky suction line	Check/Tighten
	Damaged gasket	Replace
	Diaphragm damaged	Replace
Uneven action of pump	Foreign body in ball valve, or valve is worn	Check ball valve, replace if necessary
	Air is sucked in	Check suction device
	Suction line blocked	Check/Clean
	Soiled/Leaking valve ball/valve seat	Clean/Replace
Pump does not start	No working air	Switch on and/or check compressed air supply
	Pressure regulator defective	Replace pressure regulator
Pump works but does not build up	Suction filter soiled or suction hose bent	Clean suction filter/Check suction hose

any pressure or suction power	Suction device leaky, air is sucked in	Check gasket
	Valve ball/Valve seat soiled	Clean valve ball
	Valve blocked	Foreign body in valve; rinse out pump
	Valve seat or valve ball worn	Replace valve seat/valve ball
	O-ring seal damaged	Replace
Pressure fluctuations during operation Different running noise	Diaphragm worn	Replace
Please contact our service department for assistance with other queries / problems.		

10 REGULAR CHECKS

	<p>During all inspection and maintenance work: Before opening the pump</p> <ul style="list-style-type: none"> ▪ Clean pump using detergent ▪ Shut off compressed air supply ▪ Dissipate material pressure by activating the extraction point.
---	--

10.1 Diaphragms and gaskets

- Diaphragms and gaskets are subject to natural wear and tear. We recommend regular safety checks and replacement of diaphragms and gaskets. Always change the gaskets with the diaphragms.

10.2 Hoses and pipelines

- Even when handled correctly, the useful life of hoses and pipelines is always affected by environmental factors. As a precautionary measure, all hoses and pipelines should be regularly replaced (at intervals depending on the load to which they are subjected).

11 MAINTENANCE

11.1 Replacing the diaphragm and valve parts [Drawings on page 9-10]

- Shut off compressed air supply and dissipate any remaining material pressure.
- Disconnect compressed air connection (7-8).
- Remove star grip (6) from pressure regulator (36).
- Remove cover hood (2).
- Loosen screws (11) and remove control housing (27).
- Unscrew nut (23), remove pressure disk (24) and pressure spring (25).
- Unscrew diaphragm (31) from bolt (26).
- Lubricate disk (28)!
- Clean contact surfaces of control housing.
- Firmly screw new diaphragm into bolt (26)
- When assembling, ensure that the pressure disk (24) is centered above the stem valves (35) and the control housing is screwed evenly to the pump body!
- Attach the cover hood (2) and screw in the air connection (7-8). Screw the star grip (6) into the pressure regulator (36).

- Conduct trial run.

11.2 Replacing valve parts [Drawings on pages 9-10]

- Shut off compressed air supply and dissipate any remaining material pressure.
- Unscrew double nipple (15, 22).
- Pull out ball guide (16).
- Remove valve seats (18, 19) using special tool.
- Clean valve housing.
- Replace worn and damaged parts.
- Mount new valve seat; lightly lubricate valve housing and O-ring seal beforehand.
- Rinse through pump and conduct trial run.

12 TECHNICAL DATA

	MP-100
Conveying capacity (based on water):	10 l/min (free outflow)
Material connection (outlet):	G 1 female thread or straight screw-in connection for 1" hose
Max. temperature of coating material:	0°C...+50°C
Max. pressure:	8 bar
Maximum admissible operating pressure:	8 bar
Compressed air feed:	non-lubricated, filtered
Compressed air connection:	hose nozzle NW 8/9
Air inlet pressure:	min. 4 to max. 8 bar
Transmission ratio:	1:1
Max. stroke rate (twin strokes):	120 twin str./min
Recommended stroke rate (twin strokes):	100 twin str./min
Weight:	5 Kg
Air consumption at 8 bar:	approx. 80l/min

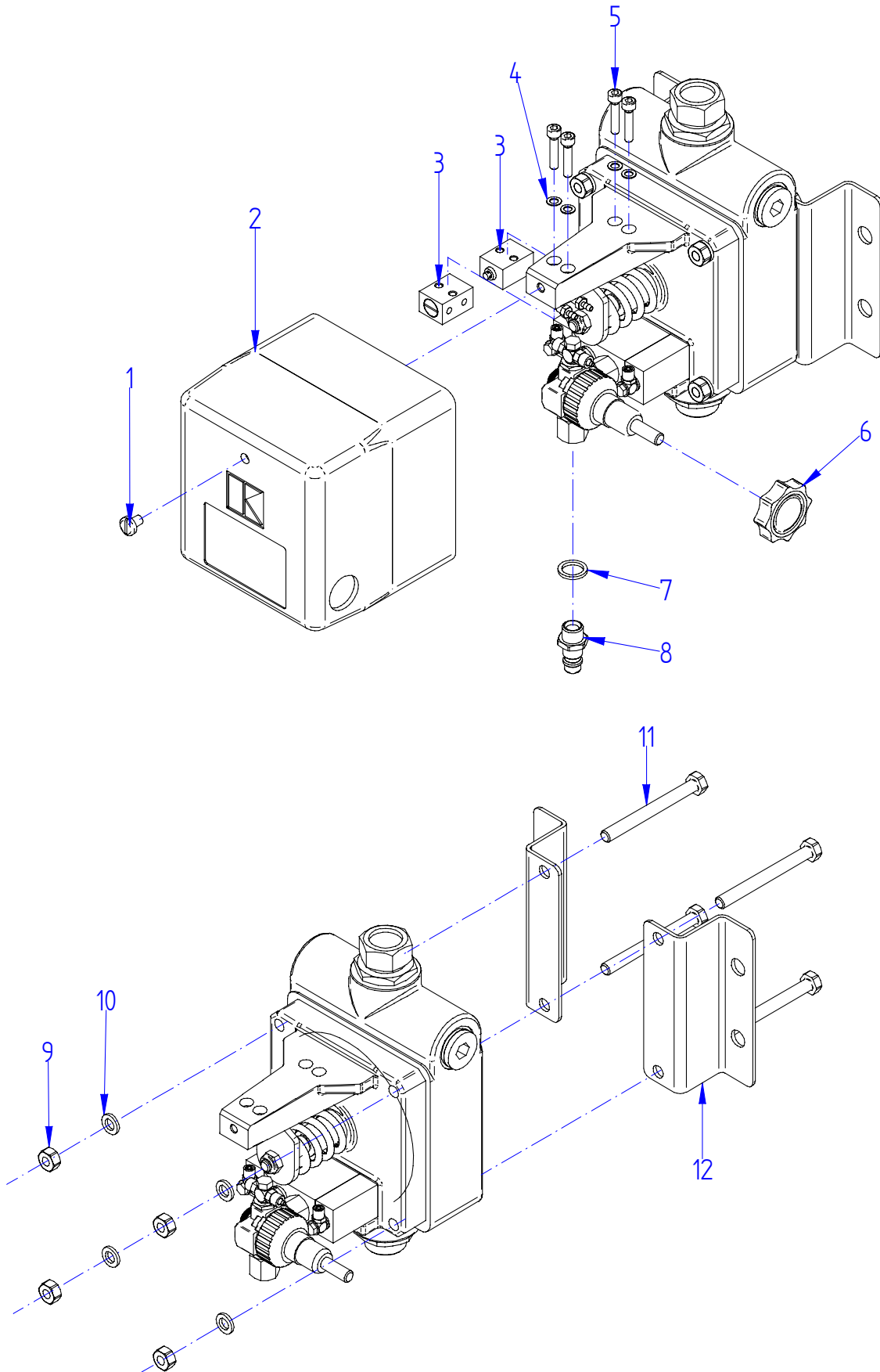

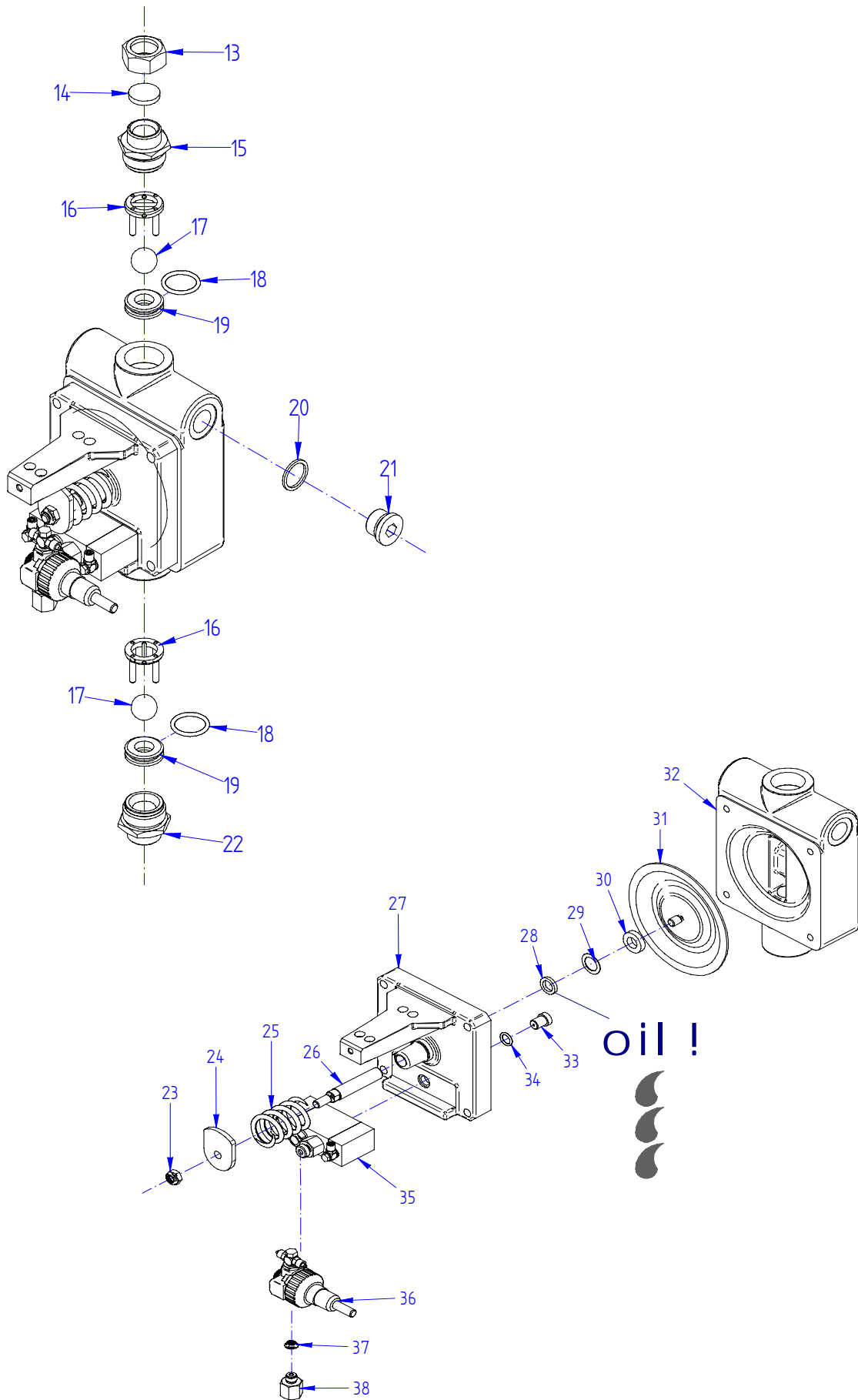

Spare parts list

Item	Designation	Article no.:
1)	screw M6x12	6500-030-0149
2)	cover hood	6500-040-2617
3)	valve housing (cmpl.)	6500-080-0332
4)	locking ring	6500-030-0707
5)	screw M5x25	6500-030-0147
6)	star grip	6500-030-1314
7)	coupling nipple (incl. Pos. 8)	6500-030-2337
8)	coupling nipple (incl. Pos. 7)	6500-030-2337-1
9)	nut	6500-030-2903
10)	washer	6500-030-1951
11)	Hex head screw M8x80	6500-030-0148
12)	fastening angle	6500-040-2659
13)	union nut	6500-040-1246
14)	gasket	6500-010-0198
15)	double nipple	6500-040-0942
16)	ball guide	6500-040-0948
17)	variable item: valve ball, stainless steel valve ball, tungsten carbide valve ball polyurethane valve ball polyamid	6500-030-2753 6500-030-2754 6500-030-2752 6500-030-2751
18)	variable item: gasket o-ring viton gasket o-ring EPDM	6500-010-0140 6500-010-0201
19)	valve seat	6500-040-0944
20)	gasket	6500-010-0112
21)	sealing screw	6500-030-2138
22)	double nipple	6500-040-0942
23)	nut	6500-030-2924
24)	pressure disk	6500-040-0951
25)	pressure spring	6500-020-0063
26)	bolt	6500-040-0952
27)	control housing	6500-040-2619
28)	Gasket (felt ring)	6500-010-0196
29)	disk	6500-030-1958
30)	gasket, slotted ring	6500-010-0197
31)	variable item: diaphragm PTFE diaphragm NBR	6500-010-0455 6500-010-0451
32)	pump housing	6500-040-2600
33)	fastening screw	6500-040-3990
34)	gasket	6500-010-0115
35)	3/2 way-valve	6500-130-0018
36)	pressure regulator	6500-090-0279
37)	filter	6500-030-1436
38)	nipple	6500-040-0896

13 TROUBLESHOOTING

Defect	Cause	Remedy
Pump does not start	<ul style="list-style-type: none"> ▪ Compressed air feed ▪ Pressure reducer ▪ Connecting hoses ▪ Control valve ▪ Control valve ▪ Stem valve 	<ul style="list-style-type: none"> ▪ Check compressed air feed ▪ Replace ▪ Replace ▪ Replace ▪ Replace
Pump works but does not build up any pressure	<ul style="list-style-type: none"> ▪ Suction filter soiled ▪ Suction device leaky, air is sucked in ▪ Material too viscous, suction height too great ▪ Valve ball and seat soiled ▪ Foreign body sucked in 	<ul style="list-style-type: none"> ▪ Clean ▪ Check, clean ▪ Check ▪ Clean ▪ Check
Irregular pump action	<ul style="list-style-type: none"> ▪ Foreign body sucked in ▪ Air is being sucked in 	<ul style="list-style-type: none"> ▪ Check ▪ Check
Air bubbles in material flow	<ul style="list-style-type: none"> ▪ Air is being sucked in ▪ Diaphragm damaged 	<ul style="list-style-type: none"> ▪ Check ▪ Replace

14 ACCESSORIES

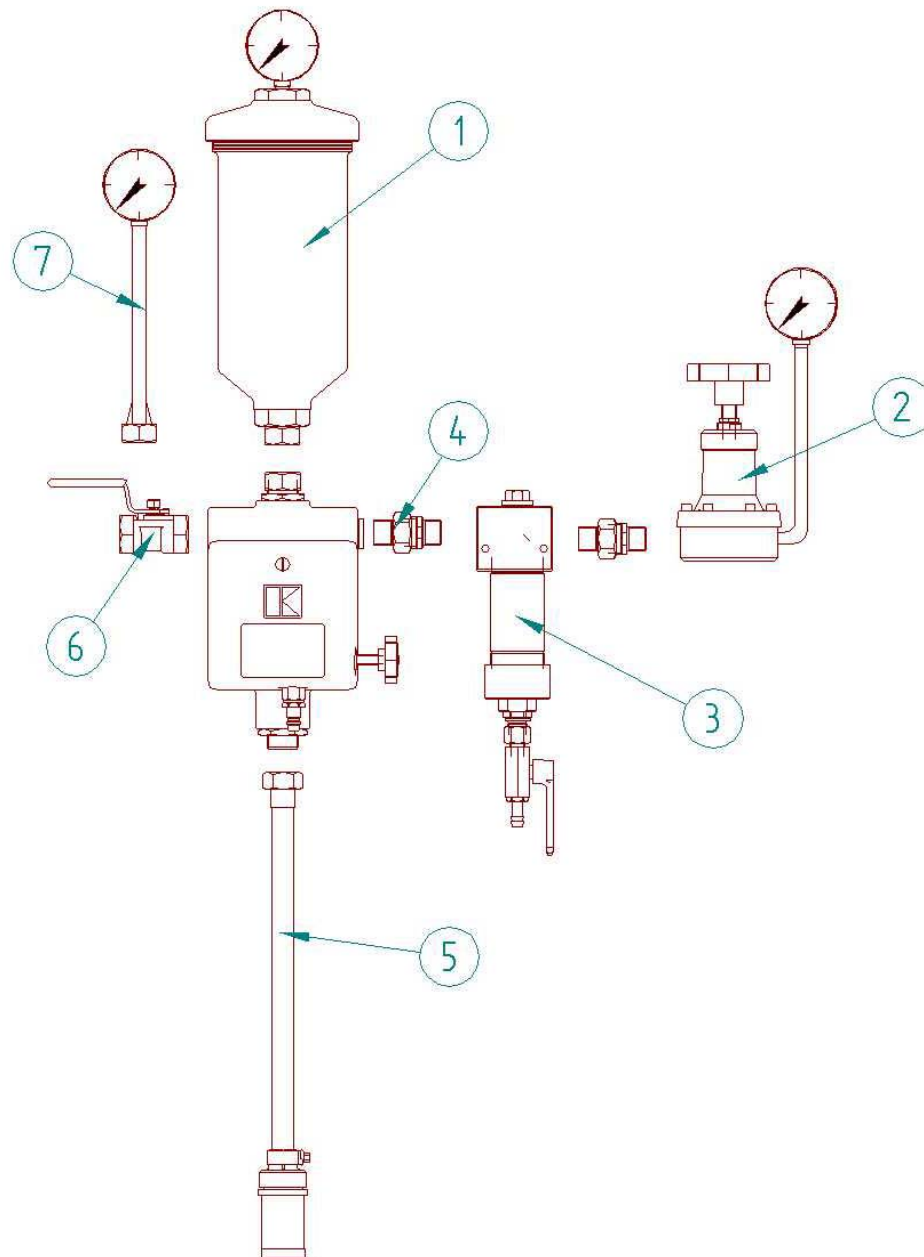

Item	Designation
1	Pressure equalisation tank for equalisation of pressure surges
2	Material pressure regulator, 0-6 bar, for adjustment of a constant material pressure
3	Material filter with different filter sizes
4	Screw connection
5	Suction device in different versions
6	Drain valve
7	Pressure pipe with pressure gauge

14.1 Suction devices (flexible)

Item no.	Article no.	Designation	Suction cage \varnothing	Hose length (mm.)
	9000-080-0776	Suction device, compl.	42	+
	9000-080-0777	Suction device, compl.	80	+
	9000-080-0778	Suction device, compl.	42	750
	9000-080-0779	Suction device, compl.	80	750
1	9000-080-0014	Suction cage	42	
1	9000-080-0066	Suction cage	80	
2	9000-030-1396	Hose clamp		
3	9000-040-0887	Suction piece		
4	9000-040-1246	Union nut		
5	9000-040-1300	Hose nozzle		
6	9000-110-0013	Suction hose		+
6	9000-110-0005	Suction hose		750
7	9000-030-1397	Hose clamp		

+ When ordering, please state hose length in mm.

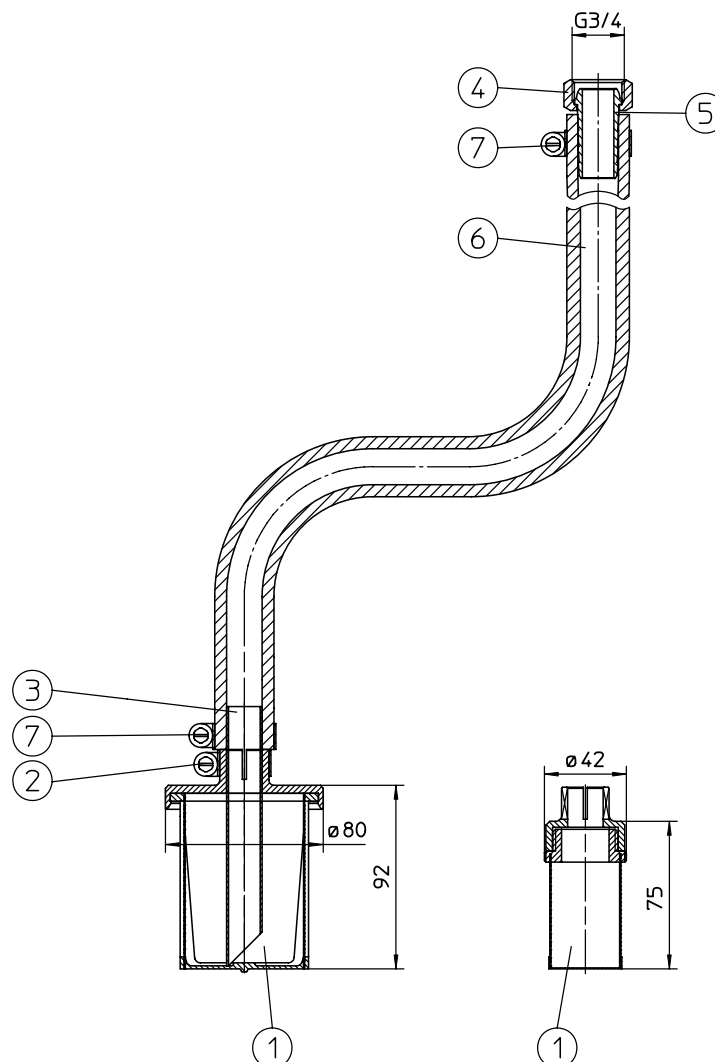

+ When ordering, please state hose length in mm.

14.2 Suction devices (angled, flexible)

Item no.	Article no.	Designation	Dim. A	Suction cage \varnothing	Hose length (mm.)
	9000-080-1714	Suction device, cmpl.	440	42	+
	9000-080-1715	Suction device, cmpl.	440	80	+
	9000-080-1716	Suction device, cmpl.	920	42	+
	9000-080-1717	Suction device, cmpl.	920	80	+
	9000-080-0288	Suction device, cmpl.	440	42	750
	9000-080-0298	Suction device, cmpl.	440	80	750
	9000-080-0774	Suction device, cmpl.	920	42	1100
	9000-080-0775	Suction device, cmpl.	920	80	1100
	9000-080-2331	Suction device, cmpl.	1100	80	1000
1	9000-080-0014	Suction cage		42	
1	9000-080-0066	Suction cage		80	
2	9000-030-1396	Hose clamp			
3	9000-040-0886	Suction pipe	440		
3	9000-040-1897	Suction pipe	920		
3	9000-040-3864	Suction pipe	1100		
4	9000-040-1246	Union nut			
5	9000-040-1300	Hose nozzle			
6	9000-110-0013	Suction hose			+
6	9000-110-0005	Suction hose			750
6	9000-110-0093	Suction hose			1100
7	9000-030-1397	Hose clamp			
8	9000-080-3511	Screw connection			

+ When ordering, please state hose length in mm.

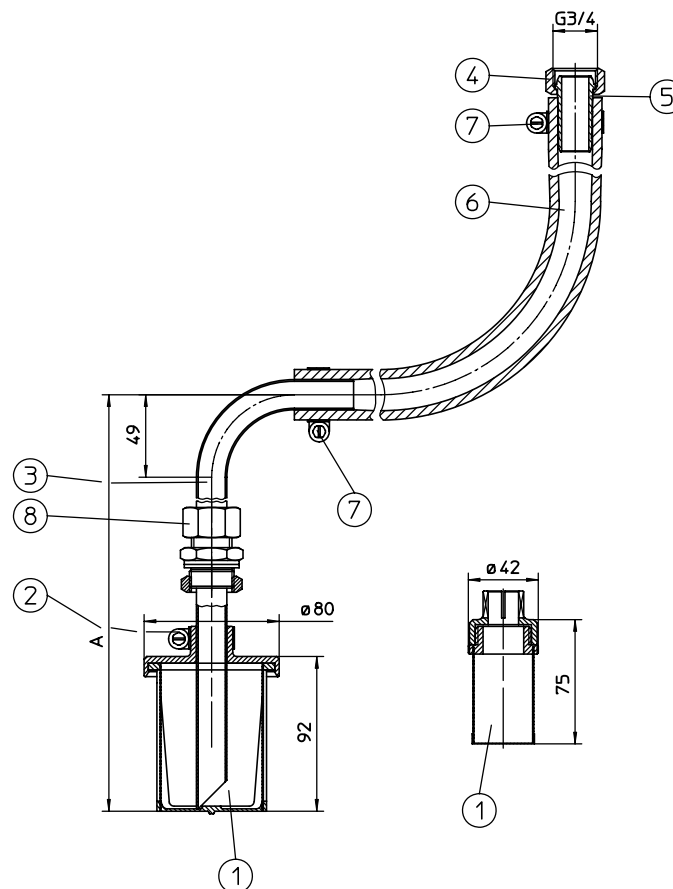

14.3 Suction devices (rigid)

Item	Article no.	Designation	Dim. A	Suction cage Ø	Applications					Pressureless Krautzberger
					MP 400	MP 100	25 l (1)	120 l (2)	200 l (3)	
	9000-090-0118	Suction device, compl.	+	42	X					
	9000-090-0119	Suction device, compl.	+	80	X					
	9000-090-0120	Suction device, compl.	+	42		X				
	9000-090-0121	Suction device, compl.	+	80		X				
	9000-090-0122	Suction device, compl.	405	42		X	X			
	9000-090-0123	Suction device, compl.	795	42		X		X		
	9000-090-0124	Suction device, compl.	885	42		X			X	
	9000-090-0125	Suction device, compl.	405	42	X		X			
	9000-090-0126	Suction device, compl.	795	42	X			X		
	9000-090-0127	Suction device, compl.	885	42	X				X	
	9000-090-0128	Suction device, compl.	405	80		X	X			
	9000-090-0129	Suction device, compl.	795	80		X		X		
	9000-090-0130	Suction device, compl.	885	80		X			X	
	9000-090-0131	Suction device, compl.	405	80	X		X			
	9000-090-0132	Suction device, compl.	795	80	X			X		200 l / 250 l
	9000-090-0133	Suction device, compl.	885	80	X				X	
	9000-090-2844	Suction device, compl.	547	80		X				50 l
	9000-090-1278	Suction device, compl.	540	80	X					50 l
	9000-090-1279	Suction device, compl.	640	80	X					100 l / 150 l
	9000-090-1283	Suction device, compl.	940	80	X					300 l / 350 l / 400 l
	9000-090-1284	Suction device, compl.	1040	80	X					450 l / 500 l
1	9000-080-0014	Suction cage		42						
1	9000-080-0066	Suction cage		80						
2	9000-030-1396	Hose clamp								
3	9000-080-0076	Suction pipe	+		X					
3	9000-080-0077	Suction pipe	+			X				
3	9000-080-0078	Suction pipe	405			X	X			
3	9000-080-0079	Suction pipe	795			X		X		
3	9000-080-0080	Suction pipe	885			X			X	
3	9000-080-0081	Suction pipe	405		X		X			
3	9000-080-0082	Suction pipe	795		X			X		200 l / 250 l
3	9000-080-0083	Suction pipe	885		X				X	
3	9000-080-3140	Suction pipe	547			X				50 l
3	9000-080-1325	Suction pipe	540		X					50 l
3	9000-080-1326	Suction pipe	640		X					100 l / 150 l
3	9000-080-1330	Suction pipe	940		X					300 l / 350 l / 400 l
3	9000-080-1331	Suction pipe	1040		X					450 l / 500 l
4	9000-040-1246	Union nut								

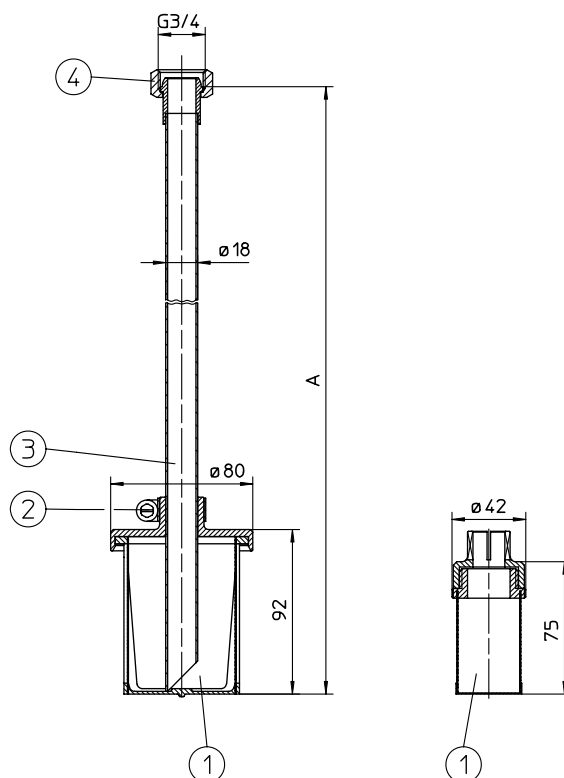

- 1) 25 l hobcock container, height 385 mm
- 2) 120 l plastic standard barrel, height 795mm
- 3) 200 l barrel with lid M7 DIN 6644, height 871 mm

+ When ordering, please state dimension A!

14.4 Pressure equalisation tank

Pressure equalisation tank, cmpl. (brass screw connection 9040-090-0088)

Item no.	Article no.	Designation
	9040-090-0088	Pressure equalis. tank, cmpl.
1	9040-080-0098	Container, cmpl.
2	9040-100-0475	Cover
3	9040-010-0162	Gasket
4	9040-030-1039	Pressure gauge, 0-10 bar
	9040-080-0099	Cover, cmpl. comprising items 2 to 4

Pressure equalisation tank, cmpl. (stainless steel screw connection 9041-090-0087)

Item no.	Article no.	Designation
	9041-090-0087	Pressure equalis. tank, cmpl.
1	9041-080-0097	Container, cmpl.
2	9041-100-0475	Cover
3	9041-010-0162	Gasket
4	9041-030-1039	Pressure gauge, 0-10 bar
	9041-080-0099	Cover, cmpl. comprising items 2 to 4

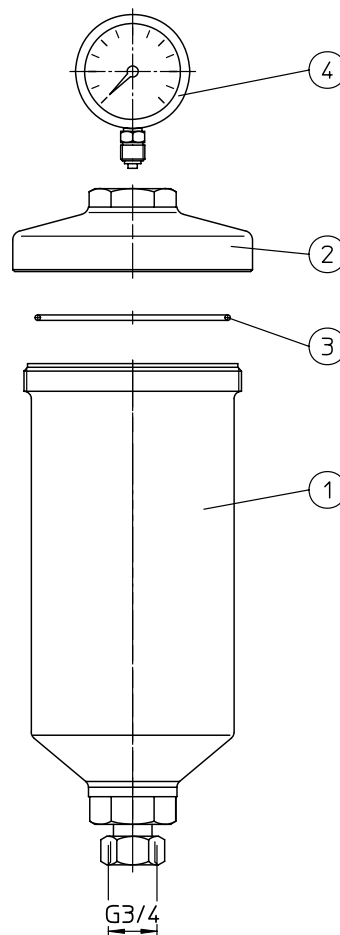

14.5 Pressure pipe

Pressure pipe, compl.(brass, 9035-080-0338)

Item no.	Article no.	Designation
	9035-080-0338	Pressure pipe, compl.
1	9035-080-0340	Pressure pipe
2	9035-040-1246	Union nut
3	9035-030-1039	Pressure gauge, 0-10 bar

Pressure pipe, compl., stainless steel 9036-080-0339)

1	9036-080-0340	Pressure pipe
2	9036-040-1246	Union nut
3	9036-030-1039	Pressure gauge, 0-10 bar

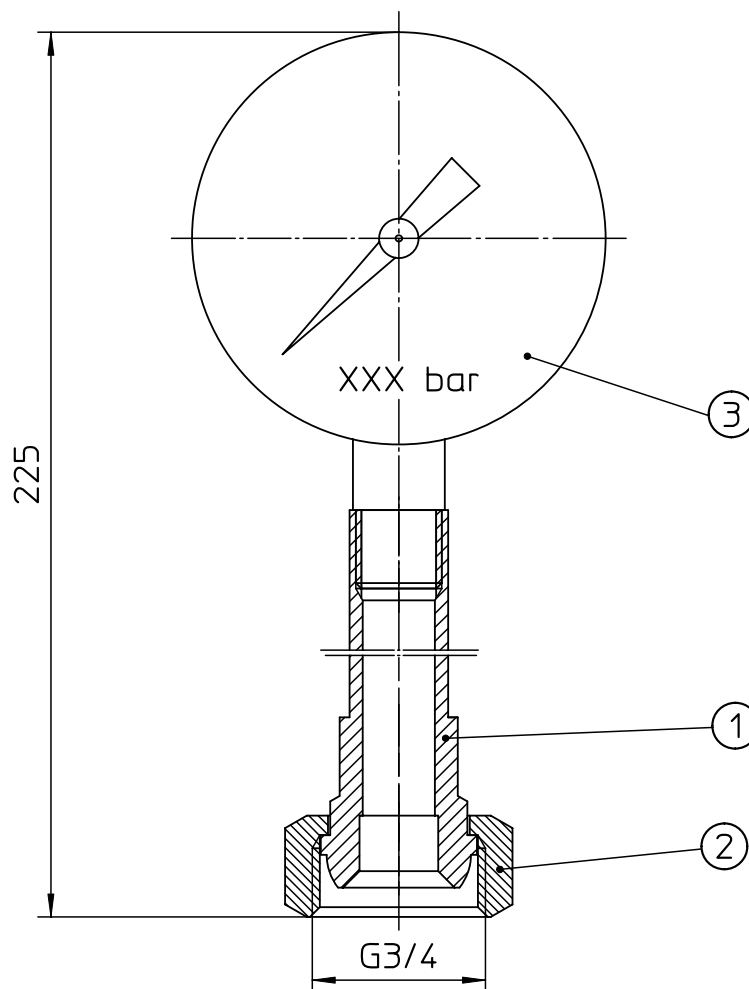

YOUR NOTES

YOUR NOTES

YOUR NOTES