

Operating instructions and spare parts list

DOK-269-GB Rev. 1

description **airless spray appliance**

type **15-50**

Order-No.: 7220-000

- keep for further use -

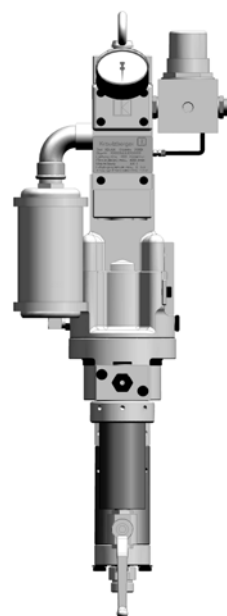

Krautzberger 

Description	Piston-Pump
Type	15-50
Order.No.	7220-000

The Airless process

Atomization and agent application are brought about without the use of air, thus the term Airless. The agent is being atomized by squeezing it under an extremely high pressure through the small bore of the material nozzle. In the process the agent is disintegrated into individual particles.

The pressure required for the Krautzberger Airless process may attain up to **480bar** and is generated by compressed air operated positive-displacement piston pumps.

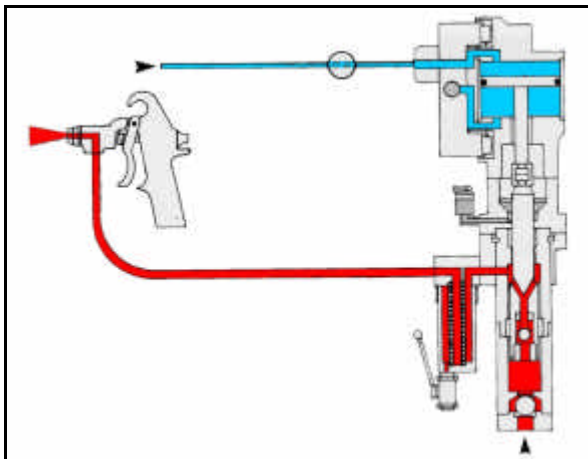

Advantages of the Airless spray

- upgraded spray performances
- instant surface coating due to a full and saturated homogeneous spray pattern and instant film formation
- reduced spray time
- increased material yield due to minimized spray fogs and low material rebound.
- fatigueless working brought about by a light and handy spray gun design equipped with only one material supply hose
- optimized atomisation even of high viscous materials

1 Method of operation of the positive-displacement pump

By means of an independently controlled air motor which is alternately applying pressure onto the motor piston, the recuperator piston of the pump is moved upwards and downwards.

Air motor and recuperator piston are interconnected via an coupling system.

Whilst moving upwards the suction valve is opened and the agent is sucked into the lower chamber of the hydraulic unit. Simultaneously the pressure valve located in the piston is being closed and the recuperator piston feeds the agent into the hydraulic unit.

The set spray pressure and the adopted nozzle size determine the stroke frequency, the air consumption, and thus the respective spray performance of the positive-displacement pump.

All agent conveying pump components consist of special steel 18/8

2 Mounting and installation

The Airless pump is to be installed in such a way as to render it easily accessible for maintenance and cleaning purposes.

The pump holder is provided with an earthing screw to which the ground wire must be connected in order to ground the static charge generated by the agent flowing within the hose.

Connect the Airless pump only with a heavy duty compressed-air supply net: designed for a maximum compressed air consumption.

PRIOR TO START-UP, CLOSE THE PRESSURE REGULATOR OF THE

Description	Piston-Pump
Type	15-50
Order.No.	7220-000

AIRLESS PUMP BY COUNTER-CLOCKWISE TURNING THE HAND-WHEEL.

The piping supplying compressed air to the Airless-pump should have a nominal width of 9.

Furthermore we recommend to provide the compressed air supply net with an oil- and water separator in order to prevent foreign bodies from penetrating into both air motor and independently operating control system.

If need be a compressed air-oiler with deicing agent maybe installed between airless pump and oil/water separator.

Use only the original suction gear in order to ensure proper pump sucking.

Engage spray gun`s safety catch and connect the material supply hose at the outlet of the high-pressure filter.

WHEN IT COMES TO MATERIAL SUPPLY HOSES WITH SAFETY CONDUCTOR IN ORDER TO PREVENT ELECTROSTATIC CHARGES FROM BEING GENERATED.

CAUTION:

With regard to operating the Airless pump we prefer to the safety rules edited and published by the applicable employers liability insurance.

3 Start-up

- Entirely close pressure regulator at motor
- connect compressed air-hose (max. 8bar)
- in case the pump is provided with a material filter, (strongly recommended by us) a filter mesh matching the nozzle requirements must be used. See table

- Fill rinsing agent into the rinsing chamber, until the sight glass shows a 70% fillin level
- Slowly open pressure regulator until air motor starts working.
- Rinse the Airless pump by means of the rinsing agent in order to get the preservatives out of the pump
- put the suction hose into the spray agent
- open spray gun in order to evacuate the air still contained in the system
- When the spray agent starts to emerging from the spray gun, close spray gun and set the required working pressure at the pressure regulator (max 8bar)

CAUTION!

PAY ATTENTION TO THE PRESSURE TRANSFORMATION RATIO!

Under no-load conditions the Airless-pump must only be operated for a short time and at a slow running level.

Otherwise motor, suction valve, piston valve and the pump sealing may be damaged.

CAUTION!

The spay jet emerging from the spray gun is dangerous. For this reason aim the spray gun only downwards.

4 Switching off

Switching-off

- Entirely close pressure regulator at motor
- disconnect spray gun and render the system pressureless.
- remove and clean the spray nozzle

Description	Piston-Pump
Type	15-50
Order.No.	7220-000

- remove suction hose out of the spray agent and put it in a thinner
- slowly open pressure regulator whilst the spray gun is being opened, until the air motor starts working
- rinse spray gun and pump by means of a thinner. In the process make sure that the motor runs at a slow level only
- for rough cleaning of the filter during rinsing , shortly open the cock at filter

Maintenance

Daily check rinsing agent level during operation. Sight glass must show a 70% filling level.

In case the rinsing agent is contaminated by the spray agent, replace the rinsing agent. If, after a short time only, the rinsing agent should again be contaminated or should the rinsing agent level displayed by the sight glass increase, we recommend to replace the gasket set, item 22 and item 30.

By replacing these gasket sets, the recuperator piston prevented from being worn out prematurely.

We recommend to open the material filter at fixed intervals in order to clean the filter housing, mesh inclusive.

CAUTION!

Prior to opening material filter refer to instructions

Description	Piston-Pump
Type	15-50
Order.No.	7220-000

5 Technical data

Air consumption

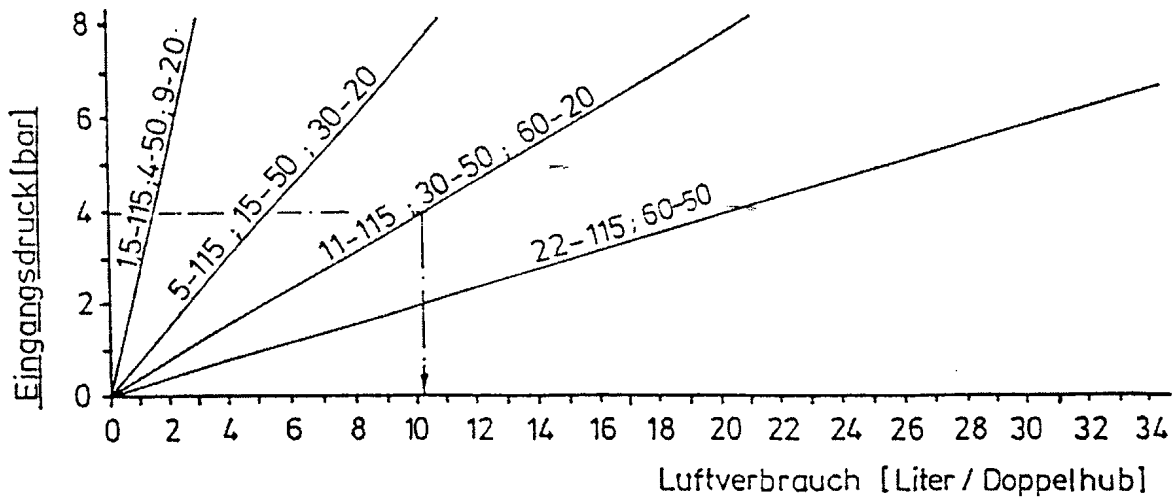

Example

input air pressure: 4,0bar
 pump type: 4-50
 air consumption/double stroke: 5.45litres

pressure transformation ratio	15:1
delivery volume/double stroke	100ccm
max. recommended double strokes/minute	50
max. air pressure	8bar
max. spray agent pressure in bar	120bar
recommended delivery volume	5,0l/min (50 double strokes/minute)
max. delivery volume	10,0l/min (100 double strokes/minute)

Description	Piston-Pump
Type	15-50
Order.No.	7220-000

6 Trouble shooting guide

kind of malfunction origin of malfunction (unit)	pump does not start or Stops running durin operation	no or insufficient pump sucking	spray pressure to low	uneven operation of pump	pump continues running even though spray gun is closed	pump feeds agent into rinsing chamber	iced control
drive	clean control and defective parts			clean control and defective parts			pump runs too fast
hydraulic unit		insufficient venting, leaking screwing between hydraulic unit and suction gear		insufficient venting, leaking screwing between hydraulic unit and suction gear			
suction gear		mesh basket obstructed		mesh basket obstructed			
high pressure filter	filter contaminated, check for passage and cleanliness						
high pressure material hose	choked hose, check for passage and cleanliness						
suction/pressure valve		worn or blocked, replace defective parts					
sealing sets		leaking gaskets				upper gasket set leaking	
atomizer nozzle	nozzle bore choked		excessive nozzle bore				excessive nozzle bore
pressure reducing valve	air pressure too low		air pressure too low				
compressed air piping	insufficient air quantity, air pressure too low		insufficient air quantity, air pressure too low				
spray agent		viscosity too high					

Description	Piston-Pump
Type	15-50
Order.No.	7220-000

7 Units of the airless-pump 15-50

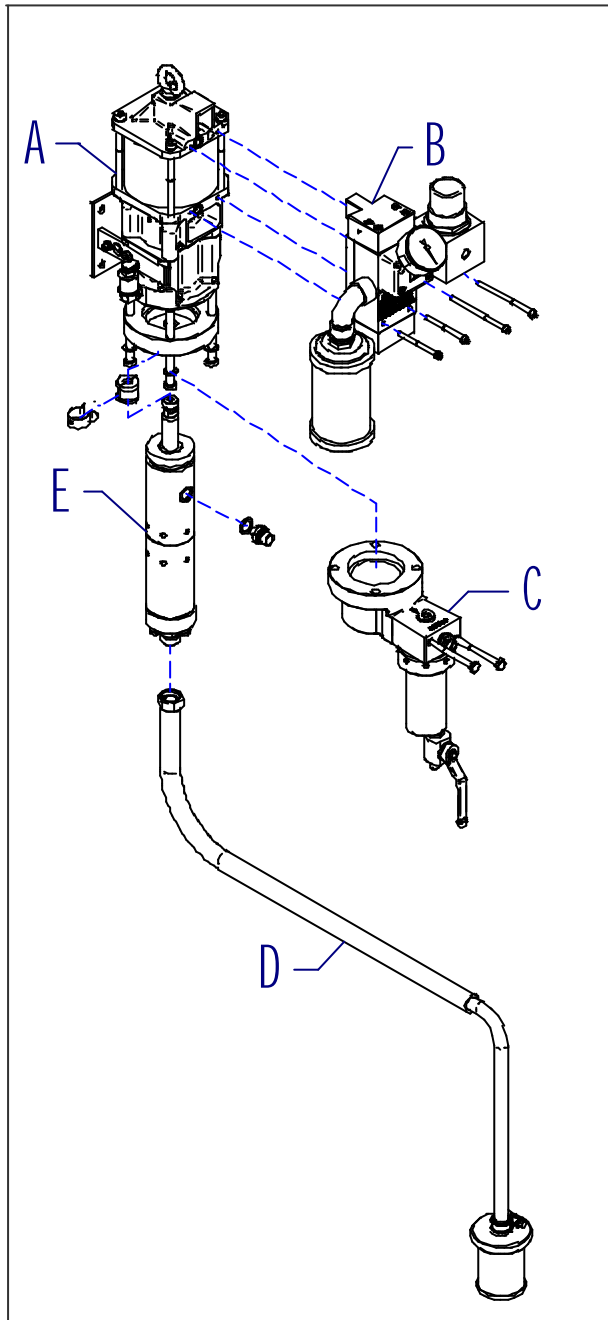

Item	designation	Order No.
A	motor, compl.	7220-080-0456
B	control unit, compl.	7220-080-3141
E	Hydraulic section, compl.	7220-090-0008
C	filter compl.	7220-080-0013
D	suction gear, compl.	7220-080-0298

Description	Piston-Pump
Type	15-50
Order.No.	7220-000

Spare parts list motor 125

Item	Description	Order-No.	Number of items
1	Screw	7220-030-0143	1
2	Washer	7220-030-2867	1
3	Screw M8x115	7220-030-0512	4
4	Circlip	7220-030-0714	4
5	Upper part motor	7220-040-0439	1
6	Seal, O-Ring	7220-010-0255	2
7	Cylinder tube	7220-040-0440	1
9	Countersunk-Screw, M10x25	7220-030-0354	1
10	Piston	7220-040-0441	1
11	Seal, O-Ring	7220-010-0254	1
12	Piston rod	7220-040-0030	1
13	Slotted ring	7220-010-0898	2
14	Bushing	7220-040-0041	1
16	Washer	7220-040-0042	1
17	Circlip	7220-030-0718	1
18	Lower part motor	7220-040-0438	1
19	Tapped rod	7220-040-0034	2
20	Slotted ring, NBR 90	7220-010-0247	2
21	Washer	7220-030-2857	2
22	Pressure spring	7220-020-0076	2
23	Washer	7220-030-2856	2
24	Circlip	7220-030-0719	2

Description	Piston-Pump
Type	15-50
Order.No.	7220-000

Spare parts drawing motor

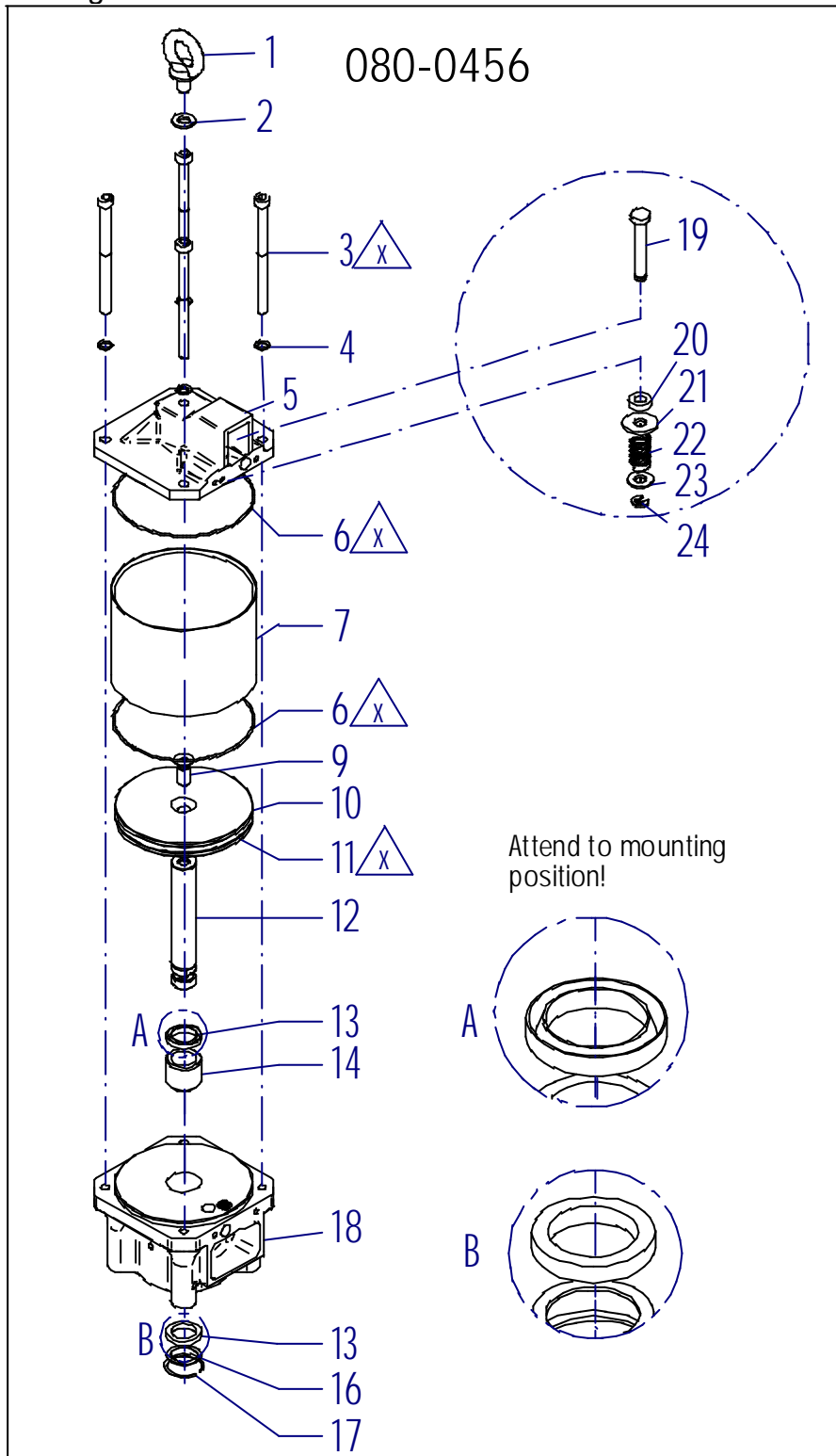

x = lightly grease parts

Description	Piston-Pump
Type	15-50
Order.No.	7220-000

spare parts list control unit, 8bar pressure

Item	Designation	Order-no	Number of items
1	O-Ring NBR 70	7220-010-0241	2
2	Controll valve complete	7220-130-0305	1
3	Screw M6x95 (M-70) Screw, M6x100	7220-030-0533 7220-030-0315	2
4	Screw M6x68 (M-70) Screw, M6x70	7220-040-4896 7220-030-0310	2
5	Safety disk , VA 1.4122	7220-030-0706	4
6	Preussure gauge, 10bar	7220-030-0720	1
7	Mini-safety valve 8,0bar Mini-safety valve 6,0bar	7220-130-0179 7220-030-2838	1 1
8	Gasket, Copper	7220-010-0244	1
9	Double nipple, brass, 2xG3/4"	7220-030-1991	2
10	Gasket, copper	7220-010-0287	2
11	Pressure regulator	7220-030-1313	1
12	Gasket	7220-010-0251	1
13	Sound absorber	7220-030-0711	1
14	Bend	7220-030-2020	1
15	Extension IG 3/4"-AG1/2"	7220-030-0708	1
16	Rapid srew connection, Messing, PH 3-5	7220-030-2406	1
17	Hose, max. 8bar, l=82mm	7220-100-0439	1
18	swivle screw connection, brass, PH 3-5	7220-080-0207	1
19	Screw, M6x35	7220-030-0294	8
20	Safety disk	7220-030-0706	8
21	Housing	7220-040-4618	2
22	O-Ring, NBR 70	7220-010-0243	1
23	Connector	7220-040-0446	1
24	Safety bolt, VA 1.4122	7220-030-0706	2
25	Screw, M6x35	7220-030-0294	2
26	O-Ring, NBR 70	7220-010-0636	6
27	Control piston	7220-010-0835	2
28	O-Ring, EPDM	7220-010-0188	6
29	Take-up sleeve	7220-040-3902	2
30	Air distributor	7220-040-0316	1
31	Grip sleeve	7220-030-2720	1
32	Gasket	7220-010-0245	1
33	Housing	7220-040-4617	1
34	Type label	7220-040-1874	1
35	O-Ring, NBR 70	7220-010-0352	2
36	O-Ring, NBR	7220-010-0741	1
37	O-Ring, NBR 70	7220-010-0352	6
38	Slide valve, Alu	7220-030-3852	1
39	Inner part, brass	7220-030-4141	1
40	Spacer	7220-040-3329	2

Description	Piston-Pump
Type	15-50
Order.No.	7220-000

Spare parts drawing control unit

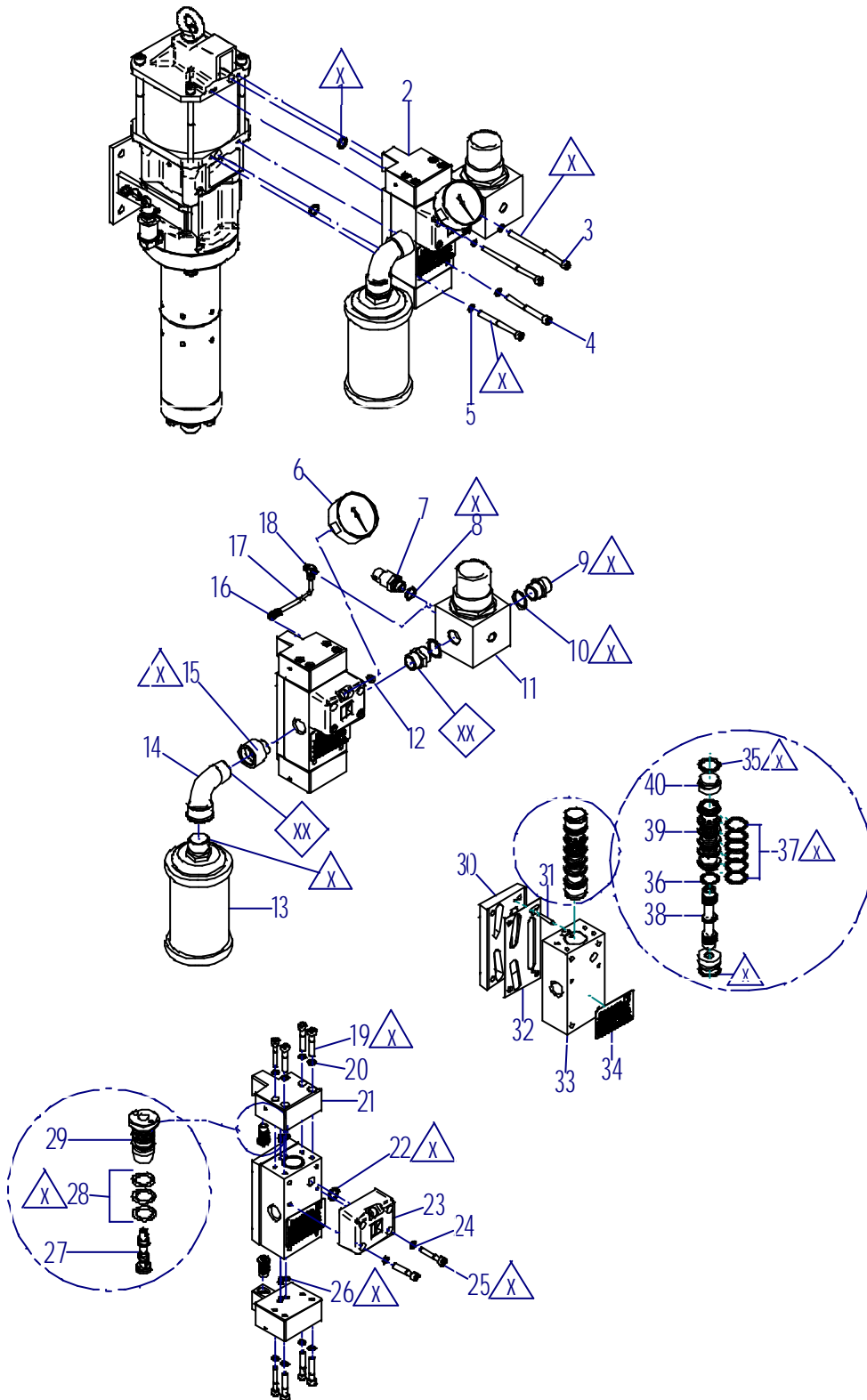

x = lightly grease parts

Description	Piston-Pump
Type	15-50
Order.No.	7220-000

spare parts list hydraulic system:

Item	Designation	Order-No.	Number of items
1	Ring	7220-040-3004	1
2	Slotted ring, PTFE Slotted ring, Protosil-Tiokol	7220-010-0269* 7220-010-0273	5
3	Ring	7220-040-0592	1
4	Upper part tube	7220-040-0617	1
5	Piston (cpl)	7220-080-0008	1
5.1	Piston	7220-040-0620	1
5.2	Ball valve	7220-040-0599	1
5.3	Ball	7220-030-2749	1
5.4+5.5	Sealing screw, cpl.	7220-080-0009	1
5.4	Ball valve seat		1
5.5	Sealing screw		1
6	Ring	7220-040-0593	1
7	Slotted ring, PTFE Slotted ring, Protosil-Tiokol	7220-010-0270* 7220-010-0274	5
8	Ring	7220-040-3005	1
9	Gasket, UHMW-PE	7220-010-0268*	1
10	Lower part tube	7220-040-0616	1
11	Ball	7220-030-0701	1
12	Pump fastener (cpl.)	7220-080-0007	1
12.1	Ball valve seat		1
12.2	Pump fastener	7220-040-0621	1
13	Gasket, UHMW-PE	7220-010-0264*	1
14	Gasket, Copper	7220-010-0288*	1
15	Double nipple G3/4"AG	7220-040-0025	1
16	Disk M8, stainlees steel	7220-030-2874	4
17	Hexagonal nut M8x40	7220-030-0499	4
*	Gasket set	7220-010-0869	

Description	Piston-Pump
Type	15-50
Order.No.	7220-000

spare parts drawing hydraulic system:

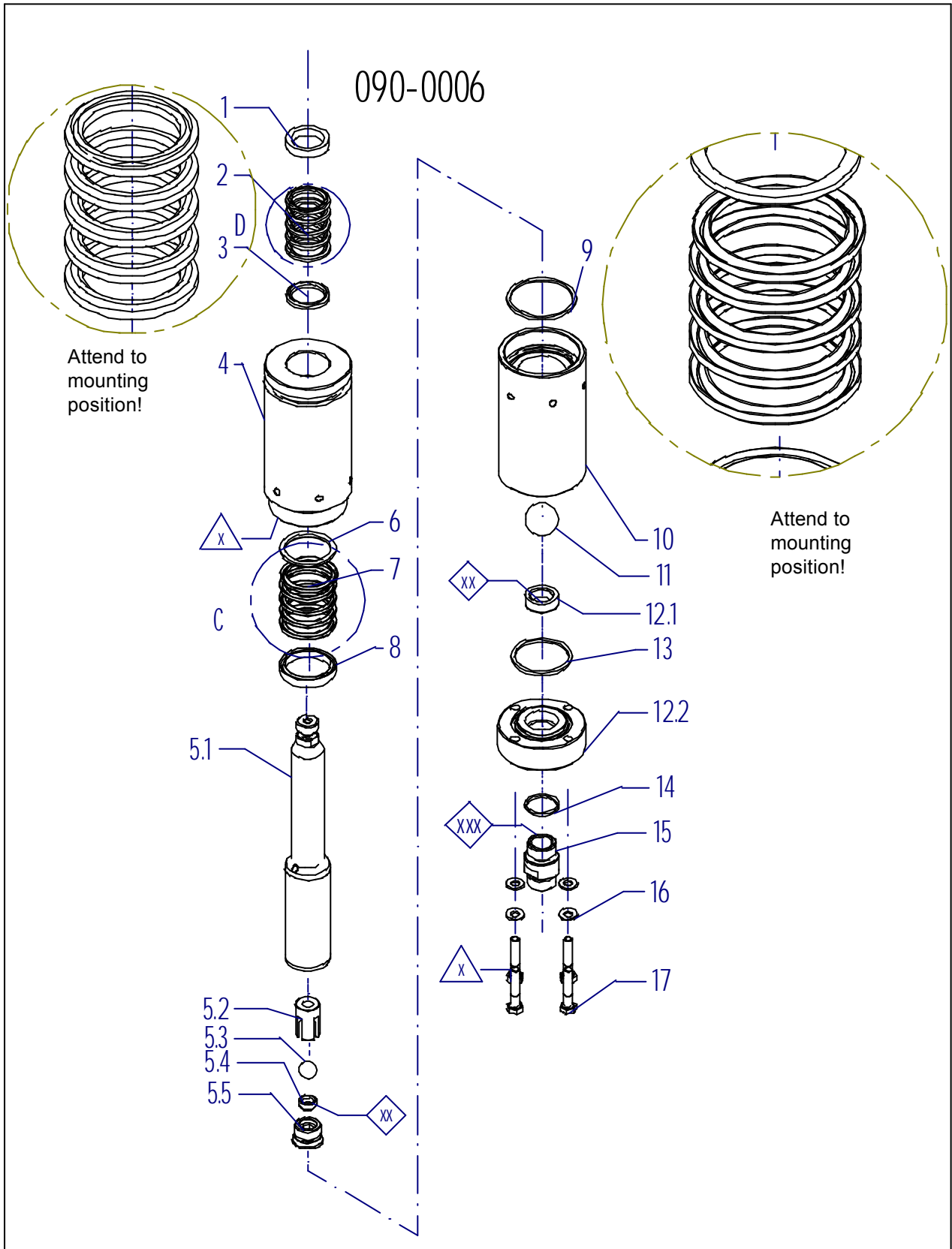

x = lightly grease parts

Description	Piston-Pump
Type	15-50
Order.No.	7220-000

Rinsing chamber and pump holder

x = lightly grease parts

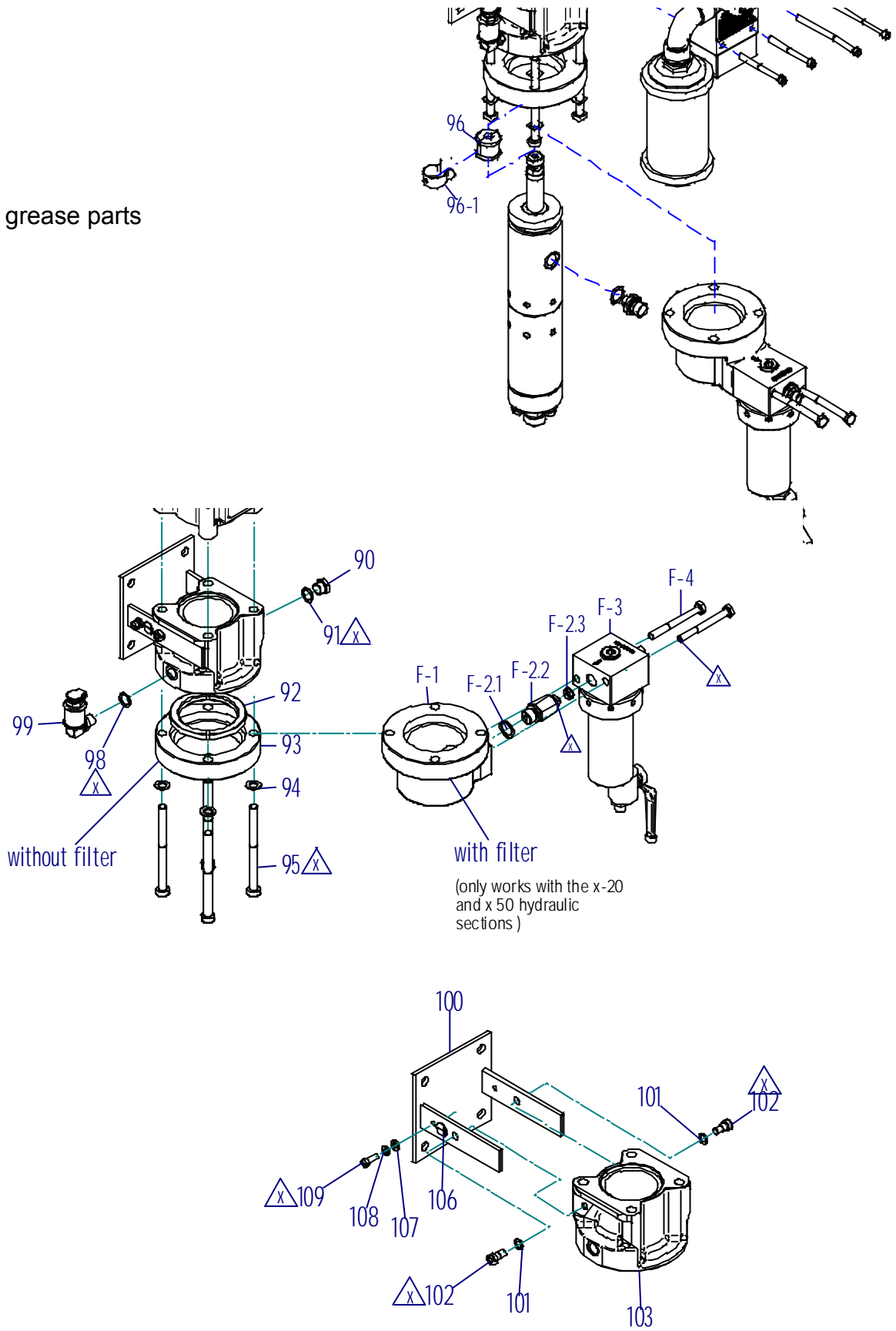

Description	Piston-Pump
Type	15-50
Order.No.	7220-000

Item	Designation	Order-No.	Number of items
90	Screw, MS	030-0516	1
91	Gasket, Cu	010-0244*	2
92	ring X/20 ring X/50	040-0460 040-0461	
93	clipping X/20 clipping X/50	040-0458 040-0459	
94	disk disk (x-20, x-50, x-115)	030-2869 030-0704	4
95	Hexagonal screw M10x120 Hexagonal screw M10x160 (only 115 hydraulic-systems)	030-0514 030-2963	4
96	Coupling (xx-20, 4-50, 15-50, 30-50) Coupling (60-50 + 22-115)	040-0062 080-0585	1
96-1	Spring	020-0150	1
98	Gasket	010-0244*	1
99	Gauge	030-1879	1
100	Pump holder	080-0006	1
101	Safety disk	030-0714	2
102	Hexagonal nut M8x16	030-0524	2
103	Rinsing chamber X/20 Rinsing chamber X/50 Rinsing chamber X/115	040-0060 040-0455 040-0605	1
106	label	040-1878	1
107	Disk, brass	030-2863	1
108	Serrated washer	030-2894	1
109	Hexagonal nut M6x16	030-0274	1
*	Gasket set	7220-010-0869	

Version build-on filter		
Item	Designation	Order-No.
F-1	Filter bracket X/20 Filter bracket X/50	040-0456 040-0457
F-2	Filter connection cpl. X/20 Filter connection cpl. X/50	080-0034 080-0035
F-2.1	Gasket copper	010-0260*
F-2.2	Filter connection X/20 Filter connection X/50	040-0602 040-0603
F-2.3	Slotted ring	010-0265*
F-3	Filter cpl.	080-0013
F-4	Hexagonal nut M8x80 washer	030-0515 030-0714
*	Gasket set	7220-010-0869

Description	Piston-Pump
Type	15-50
Order.No.	7220-000

EG-Konformitätserklärung CE Declaration of Conformity, Déclaration de conformité européenne, Declaración de conformidad CE

gemäß Anhang II A der EG – Maschinenrichtlinie 98/37/EG in acc. with Annex II A of the EC Machine Directive 98/37/EC, Selon la directive européenne 98/37/CEE, annexe II A, relative aux machines, según Anexo II A de la Directiva sobre maquinaria CE 98/37/EG



Krautzberger GmbH
Stockbornstraße 13
65343 Eltville am Rhein

HIERMIT ERKLÄREN WIR, DASS FOLGENDE PRODUKTE We hereby declare that the following product, garantissons que la version livrée des machines mentionées ci-dessous, Por la presente declaramos que el siguiente producto

Bezeichnung Designation, Désignation, Denominación Kolbenpumpen 30-10, 9-20, 30-20, 60-20, 4-50, 15-50, 30-50, 60-50, 1-115, 5-115, 11-115, 22-115

Geräte-Nummer Unit no., N° de l'appareil, Núm. aparatos **7110, 7100, 7120, 7140 7200, 7220, 7240 7260, 7300, 7320, 7340 7360**

Funktion Function, Fonction, Funcionamiento **Druckluft betriebene Verdrängerkolbenpumpen zur Druckbeaufschlagung von flüssigen bis hochviskosen Medien** Compressed air-driven pump for painting and coating applications, Pompe à commande pneumatique étudiée pour répondre aux besoins de la technologie de pulvérisation, Bomba accionada por aire comprimido para el sector de pintura y recubrimientos

IN DER GELIEFERTEN AUSFÜHRUNG FOLGENDEN BESTIMMUNGEN ENTSPRICHT complies with the following provisions in its delivered version:, satisfait aux exigences suivantes :, de la versión suministrada responde a las siguientes disposiciones:.

- EG-Maschinenrichtlinie 98/37 EG EC Machine Directive 98/37/EC, Directive européenne 98/37/CEE relative aux machines, Directiva sobre maquinaria CE 98/37/EG

FOLGENDE HARMONISIERTE EU-NORMEN WURDEN ANGEWENDET: The following harmonised EU standards were applied:, Les normes d'harmonisation européennes suivantes ont été appliquées :, Se han aplicado las siguientes normas UE armonizadas:

- DIN EN ISO 12100 Teil 1 und 2
- DIN EN 809
- DIN EN 12639
- DIN EN 1050

FOLGENDE NATIONALE NORMEN WURDEN ANGEWENDET The following national standards were applied:, Les normes nationales suivantes ont été appliquées :, Se han aplicado las siguientes normas nacionales:.

- DIN 24289 Teil 1 und 2
- DIN 24299 Teil 1 und 2

Datum / Unterschrift Date / Signature, Date/ signature, Fecha / Firma 25.05.2004

i.A. 

Angaben zum Unterzeichner Leiter Konstruktion Head of Design, Directeur de la construction, Director de diseño

M. Stoffels